

2023-2024  
INVERNO WINTER



IT +39 0221117815  
IT +39 335 7600875  
EN/FR +39 3425447140  
ES +34 664 66 64 26  
ES +34 664 66 64 28

SINEDITALIA.COM  
CAMINETTIDAPARETE.IT  
RISCALDATOREPERESTERNO.IT  
CHIMENEALECTRICAPARED.ES  
CALEFACTOREXTERIOR.ES

INFO@SINEDITALIA.COM



## CAMINETTI DA INCASSO

*INSTALLAZIONE ANCHE A FILO MURO. UNICI IN EUROPA*

I caminetti da Incasso Sined sono gli modelli in Europa con certificazioni di risparmio energetico ERP2009/125/CE. Funzionamento in base alla temperatura reale, grazie al sensore di temperatura, al termostato e al timer settimanale.

Conformità alle direttive UE Verificata da una società di certificazione esterna Europea.

## RECESSED ELECTRIC FIREPLACE

*IN-WALL INSTALLATION. UNIQUE MODEL IN EUROPE.*

Sined recessed fireplaces are the models in Europe with energy-saving certification ERP2009/125/EC. Operation based on actual temperature, thanks to temperature sensor, thermostat and weekly timer.

Compliance with EU directives Verified by an external European certification company.

## CHEMINÉE ÉLECTRIQUE ENCASTRÉE

*INSTALLATION DANS LE MUR. MODÈLE UNIQUE EN EUROPE.*

Les cheminées encastrables Sined sont les modèles en Europe avec la certification d'économie d'énergie ERP2009/125/EC. Fonctionnement en fonction de la température réelle, grâce à la sonde de température, au thermostat et à la minuterie hebdomadaire. Conformité aux directives de l'UE Vérifiée par une société de certification européenne externe.

## CHIMENEA ELÉCTRICA EMPOTRABLE

*INSTALACIÓN DENTRO DE LA PARED. ÚNICO EN EUROPA.*

Las chimeneas empotradas Sined son los modelos en Europa con certificaciones de ahorro de energía certificación de ahorro de energía ERP2009/125/CE. Funcionamiento en función de la temperatura real, gracias al sensor de temperatura, termostato y temporizador semanal. Cumplimiento de las directivas de la UE Verificado por una empresa de certificación europea externa.

## ELEKTRISCHER UNTERPUTZKAMIN

*UNTERPUTZ-INSTALLATION. EINZIGARTIGES MODELL IN EUROPA.*

Die Sined Einbaukamine sind die Modelle in Europa mit dem Energiesparzertifikat ERP2009/125/EC. Betrieb auf Basis der tatsächlichen Temperatur, dank Temperatursensor, Thermostat und Wochenzeitschaltuhr. Übereinstimmung mit den EU-Richtlinien Verifiziert durch eine externe europäische Zertifizierungsgesellschaft.

# CAMINETTO-VULCANO

8025431019263



**CORNICE DISPONIBILE SEPARATAMENTE. CREATE IL VOSTRO CAMINO A PAVIMENTO.**

**DOPPIA MODALITA' DI FUNZIONAMENTO** solo effetto fiamma ultra realistico o riscaldante con motore PCT da 1500w sigillato ermeticamente.

Consente l'installazione a incasso completo filo muro in pareti in cartongesso o muratura, mobili o pareti in legno senza rischio di incendio.

Pannello di controllo LCD, comandi manuali e uscita e ingresso dell'aria sono posizionati nella parte frontale.

Il caminetto è imballato in una scatola di cartone rinforzato certificato.

## ITALIANO

Nuovo caminetto elettrico LED con reale effetto fiamma LED. Potenza di riscaldamento 0-750-1.500W. Braciere elettrico per tutte le stagioni, potrai usare il solo effetto fiamma senza accendere il riscaldamento. Potrai comandarlo con il telecomando a corredo o manualmente dal pannello di controllo frontale.

## FRANÇAIS

Nouvelle cheminée électrique LED avec effet de flamme LED réel. Puissance de chauffage 0-750-1,500W. Brasier électrique toutes saisons, vous pouvez utiliser uniquement l'effet de flamme sans allumer le chauffage. Vous pouvez le contrôler avec la télécommande fournie ou manuellement depuis le panneau de commande avant.

## ESPAÑOL

Nueva chimenea eléctrica de LED con efecto de llama de LED real. Potencia de calentamiento 0-750-1.500W. Brasero eléctrico para todo tipo de clima, puede utilizar sólo el efecto de la llama sin encender el calentador. Puedes controlarlo con el mando a distancia suministrado o manualmente desde el panel de control frontal.

## DEUTSCH

Neuer LED-Elektrokamin mit echtem LED-Flammeneffekt. Heizleistung 0-750-1.500W. Allwetter-Elektrokochfeld, Sie können nur den Flammeneffekt nutzen, ohne die Heizung einzuschalten. Sie können ihn mit der mitgelieferten Fernbedienung oder manuell über das vordere Bedienfeld steuern.

## ENGLISH

New LED electric fireplace with real LED flame effect. Heating power 0-750-1,500W. All-season electric brazier, you can use only the flame effect without switching on the heater. You can control it with the supplied remote control or manually from the front control panel.



**DIMENSIONI**  
49,5x60x15 CM

**PESO**  
10 KG

**COLORE**  
nero

**TIPO DI CALORE**  
termoconvettore  
750-1500W

## 60 cm



**Unici modelli in europa certificati e testati per incasso completo**

*EU directives compliance*

*LVD 2014/35/UE*

*EMC 2014/30/UE*

*DERP 2009/125/CE*

*RoHS 2011/65/EU ((UE) 2015/863)*

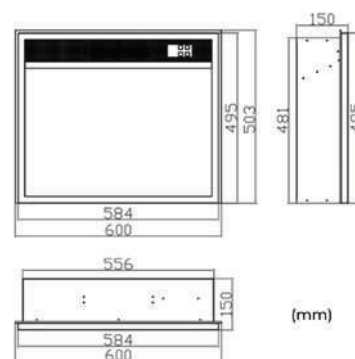

# CAMINETTO-PANAREA

8025431019270



## 75 cm



**DOPPIA MODALITA' DI FUNZIONAMENTO:** solo effetto fiamma ultra realistico o riscaldante con motore PCT da 1500w sigillato ermeticamente. Consente l'installazione a incasso completo filo muro in pareti in cartongesso o muratura, mobili o pareti in legno senza rischio di incendio. Vengono forniti con piedini per poter essere installati anche da appoggio (sul pavimento, sopra i mobili...). Pannello di controllo LCD, comandi manuali e uscita e ingresso dell'aria sono posizionati nella parte frontale. Il caminetto è imballato in una scatola di cartone rinforzato certificato Ista6, per evitare danni durante in trasporto.

### ITALIANO

Inserto per caminetti elettrici modello Panarea. Bruciatore elettrico da incasso anche per caminetti esistenti. Potenza riscaldante 1500W con telecomando incluso. Può essere usato anche con il solo effetto fiamma anche in estate. Comandabile dal telecomando o dal display sul pannello frontale

### ESPAÑOL

Inserto para chimeneas eléctricas modelo Panarea. Quemador eléctrico incorporado también para chimeneas existentes. Potencia de 1500W con mando a distancia. También se puede utilizar solo efecto llama. Se puede controlar desde el mando a distancia o panel frontal. Salida de calor por la parte superior delantera.

### ENGLISH

Insert for electric fireplaces model Panarea. Built-in electric burner also for existing fireplaces. Heating power 1500W with remote control included. Can also be used with the flame effect alone in summer. Can be controlled from the remote control or the display on the front panel. Heat output from the top front.

### FRANÇAIS

Insert pour cheminées électriques modèle Panarea. Brûleur électrique intégré, également pour les cheminées existantes. Puissance de chauffe 1500W avec télécommande incluse. Peut également être utilisé avec l'effet flamme seul en été. Peut être contrôlé à partir de la télécommande ou de l'écran du panneau avant. Sortie de chaleur par le haut de la façade.

### DEUTSCH

Einsatz für elektrische Kamine Modell Panarea. Eingebauter Elektrobrenner auch für bestehende Kamine. Heizleistung 1500W, inklusive Fernbedienung. Kann im Sommer auch allein mit dem Flammeneffekt verwendet werden. Kann über die Fernbedienung oder das Display an der Frontplatte gesteuert werden.

**DIMENSIONI**  
75x62,5x18 CM

**PESO**  
19,7 KG

**COLORE**  
nero

**TIPO DI CALORE**  
termoconvettore  
750-1500W



**Unici modelli in europa certificati e testati per incasso completo**  
EU directives compliance  
LVD 2014/35/UE  
EMC 2014/30/UE  
DERP 2009/125/CE  
RoHS 2011/65/EU ((UE) 2015/863)

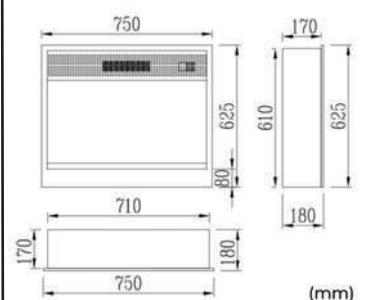

# CAMINETTO-ISPICA-108



8025431151079

## 108 cm



**DOPPIA MODALITA' DI FUNZIONAMENTO:** solo effetto fiamma ultra realistico o riscaldante con motore PCT da 1500w sigillato ermeticamente. Consente l'installazione a incasso completo filo muro in pareti in cartongesso o muratura, mobili o pareti in legno senza rischio di incendio. Vengono forniti con piedini per poter essere installati anche da appoggio (sul pavimento, sopra i mobili...).

Pannello di controllo LCD, comandi manuali e uscita e ingresso dell'aria sono posizionati nella parte frontale.

Il caminetto è imballato in una scatola di cartone rinforzato certificato Ista6, per evitare danni durante in trasporto.

### ITALIANO

Vero complemento di arredo è il caminetto elettrico nero da incasso o appoggio modello ISPICA, 108 cm di lunghezza, effetto fiamma realizzato mediante LED e regolabile come intensità, 6 livelli. Due step di potenza 750-1500W. Possibilità di comandarlo manualmente o con il telecomando incluso. Possibilità di usare il solo effetto fiamma.

### FRANÇAIS

Véritable accessoire d'ameublement, la cheminée électrique noire à encastrer ou à poser, modèle ISPICA, 108 cm de long, effet flamme créé par des LED et réglable en intensité, 6 niveaux. Deux niveaux de puissance 750-1500W. Contrôlable manuellement ou à l'aide de la télécommande fournie. Possibilité d'utiliser uniquement l'effet de flamme.

### ESPAÑOL

Un verdadero accesorio de decoración es la chimenea eléctrica negra para empotrar o de pie, modelo ISPICA, 108 cm de largo, efecto de llama creado por LED y regulable en intensidad, 6 niveles. Dos niveles de potencia 750-1500W. Se puede controlar manualmente o con el mando a distancia incluido. Posibilidad de utilizar sólo el efecto de llama.

### DEUTSCH

Ein echtes Einrichtungsaccessoire ist der schwarze Elektrokamin zum Einbau oder zum Aufstellen, Modell ISPICA, 108 cm lang, Flammeneffekt durch LEDs erzeugt und in der Intensität einstellbar, 6 Stufen. Zwei Leistungsstufen 750-1500W. Kann manuell oder mit der mitgelieferten Fernbedienung gesteuert werden.

### ENGLISH

A true furnishing accessory is the black electric fireplace for flush-mounting or standing, model ISPICA, 108 cm long, flame effect created by LEDs and adjustable in intensity, 6 levels. Two power steps 750-1500W. Can be controlled manually or with the included remote control. Possibility of using only the flame effect.

**DIMENSIONI**  
108X50X20 CM

**PESO**  
30 KG

**COLORE**  
nero

**TIPO DI CALORE**  
termoconvettore  
750-1500W



**Unici modelli in europa certificati e testati per incasso completo**  
EU directives compliance  
LVD 2014/35/UE  
EMC 2014/30/UE  
DERP 2009/125/CE  
RoHS 2011/65/EU ((UE) 2015/863)

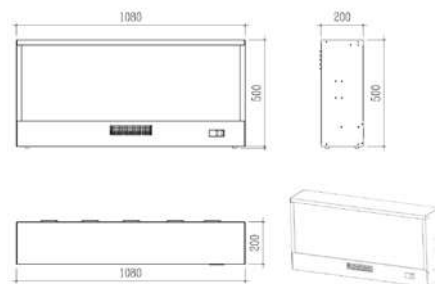

# CAMINETTO-VULTURE-150



8025431016897

## 150 cm



**DOPPIA MODALITA' DI FUNZIONAMENTO:** solo effetto fiamma ultra realistico o riscaldante con motore PCT da 1500w sigillato ermeticamente. Consente l'installazione a incasso completo filo muro in pareti in cartongesso o muratura, mobili o pareti in legno senza rischio di incendio. Vengono forniti con piedini per poter essere installati anche da appoggio (sul pavimento, sopra i mobili...). Pannello di controllo LCD, comandi manuali e uscita e ingresso dell'aria sono posizionati nella parte frontale. Il caminetto è imballato in una scatola di cartone rinforzato certificato Ista6, per evitare danni durante in trasporto.

### ITALIANO

Vero complemento di arredo è il caminetto elettrico nero da incasso o appoggio modello Vulture, 150 cm di lunghezza, effetto fiamma realizzato mediante LED e regolabile come intensità, 6 livelli. Due step di potenza 750-1500W. Possibilità di comandarlo manualmente o con il telecomando incluso.

### ESPAÑOL

Un verdadero accesorio de decoración es la chimenea eléctrica negra para empotrar o de pie, modelo Vulture, de 150 cm de longitud, efecto de llama creado por LEDs y regulable en intensidad, 6 niveles. Dos niveles de potencia 750-1500W. Se puede controlar manualmente o con el mando a distancia incluido.

### ENGLISH

A true furnishing accessory is the black electric fireplace for flush-mounting or standing, model Vulture, 150 cm long, flame effect created by LEDs and adjustable in intensity, 6 levels. Two power steps 750-1500W. Can be controlled manually or with the included remote control.

### FRANÇAIS

Un véritable accessoire d'ameublement est la cheminée électrique noire à encaster ou à poser, modèle Vulture, 150 cm de long, effet de flamme créé par des LED et réglable en intensité, 6 niveaux. Deux paliers de puissance 750-1500W. Peut être contrôlé manuellement ou avec la télécommande incluse.

### DEUTSCH

Ein echtes Einrichtungszugabe ist der schwarze Elektrokamin zum Einbau oder zum Aufstellen, Modell Vulture, 150 cm lang, Flammeneffekt durch LEDs erzeugt und in der Intensität einstellbar, 6 Stufen. Zwei Leistungsstufen 750-1500W. Kann manuell oder mit der mitgelieferten Fernbedienung gesteuert werden.

**DIMENSIONI**  
50,7x20x150 CM

**PESO**  
30 KG

**COLORE**  
nero

**TIPO DI CALORE**  
termoconvettore  
750-1500W

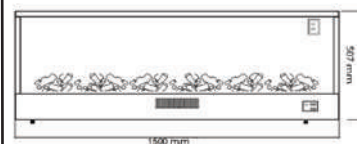
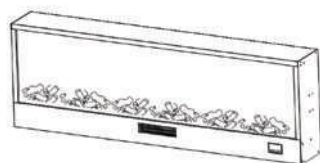

**Unici modelli in europa certificati e testati per incasso completo**  
EU directives compliance  
LVD 2014/35/UE  
EMC 2014/30/UE  
DERP 2009/125/CE  
RoHS 2011/65/EU ((UE) 2015/863)



# CAMINETTO-AMIATA-180

8025431016859

## 180 cm



**DOPPIA MODALITA' DI FUNZIONAMENTO:** solo effetto fiamma ultra realistico o riscaldante con motore PCT da 1500w sigillato ermeticamente. Consente l'installazione a incasso completo filo muro in pareti in cartongesso o muratura, mobili o pareti in legno senza rischio di incendio. Vengono forniti con piedini per poter essere installati anche da appoggio (sul pavimento, sopra i mobili...).

Pannello di controllo LCD, comandi manuali e uscita e ingresso dell'aria sono posizionati nella parte frontale.

Il caminetto è imballato in una scatola di cartone rinforzato certificato Ista6, per evitare danni durante in trasporto.

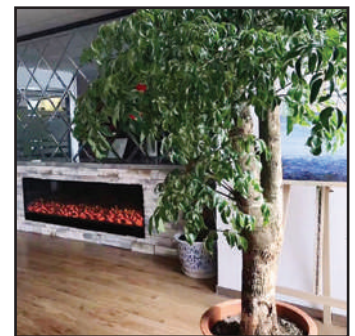

### ITALIANO

Grande caminetto elettrico da incasso e appoggio modello Amiata, 180 cm di lunghezza, effetto fiamma realizzato mediante LED e regolabile come intensità.. Due step di potenza 750-1500W. Possibilità di comandarlo manualmente o con il telecomando incluso. Possibilità di usare il solo effetto fiamma senza la funzione riscaldamento.

### ESPAÑOL

Gran chimenea eléctrica empotrada e independiente modelo Amiata, de 180 cm de longitud, efecto llama LED y de intensidad regulable. Dos niveles de potencia 750-1500W. Se puede controlar manualmente o con el mando a distancia incluido. Posibilidad de utilizar sólo el efecto de la llama sin la función de calentamiento.

### ENGLISH

Large built-in and freestanding electric fireplace model Amiata, 180 cm long, flame effect realised by LEDs and adjustable intensity. Two power steps 750-1500W. Can be controlled manually or with the included remote control. Possibility of using only the flame effect without the heating function.

### FRANÇAIS

Grande cheminée électrique encastrable et autoportante modèle Amiata, 180 cm de long, effet de flamme réalisé par des LEDs et intensité réglable. Deux paliers de puissance 750-1500W. Peut être contrôlé manuellement ou avec la télécommande incluse. Possibilité d'utiliser uniquement l'effet de flamme sans la fonction de chauffage.

### DEUTSCH

Großer Einbau- und freistehender Elektrokamin Modell Amiata, 180 cm lang, Flammeeffekt durch LED und einstellbare Intensität. Zwei Leistungsstufen 750-1500W. Kann manuell oder mit der mitgelieferten Fernbedienung gesteuert werden. Es besteht die Möglichkeit, nur den Flammeffekt ohne Heizfunktion zu nutzen.

### DIMENSIONI

50,7x20x180 CM

### PESO

36 KG

### COLORE

nero

### TIPO DI CALORE

termoconvettore

750-1500W

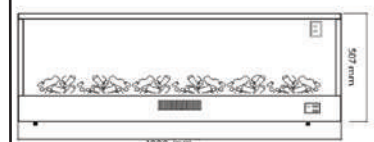
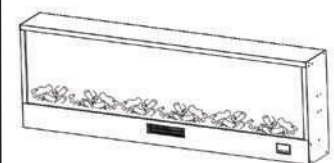

**Unici modelli in europa certificati e testati per incasso completo**

*EU directives compliance*

*LVD 2014/35/UE*

*EMC 2014/30/UE*

*DERP 2009/125/CE*

*RoHS 2011/65/EU ((UE) 2015/863)*



# CAMINETTO-ETNA-300

8025431016866 / DA ESPOSIZIONE



**3 METRI!**



**DOPPIA MODALITA' DI FUNZIONAMENTO:** solo effetto fiamma ultra realistico o riscaldante con motore PCT da 1500w sigillato ermeticamente. Consente l'installazione a incasso completo filo muro in pareti in cartongesso o muratura, mobili o pareti in legno senza rischio di incendio. Vengono forniti con piedini per poter essere installati anche da appoggio (sul pavimento, sopra i mobili...). Pannello di controllo LCD, comandi manuali e uscita e ingresso dell'aria sono posizionati nella parte frontale. Il caminetto è imballato in una scatola di legno rinforzato, per evitare danni durante in trasporto.

## ITALIANO

Imponente caminetto elettrico da incasso o appoggio modello Etna, 300 cm di lunghezza, effetto fiamma realizzato mediante LED e regolabile come intensità. Due step di potenza 750-1500W. Possibilità di comandarlo manualmente o con il telecomando incluso. Possibilità di usare il solo effetto fiamma senza la funzione riscaldamento.

## ESPAÑOL

Impresionante chimenea eléctrica empotrada o independiente modelo Etna, de 300 cm de longitud, efecto de llama LED regulable en intensidad. Dos niveles de potencia 750-1500W. Se puede controlar manualmente o con el mando a distancia incluido. Posibilidad de utilizar sólo el efecto de la llama sin la función de calentamiento.

## ENGLISH

Impressive built-in or free-standing electric fireplace model Etna, 300 cm long, flame effect realised by LED and adjustable in intensity. Two power steps 750-1500W. Can be controlled manually or with the included remote control. Possibility of using only the flame effect without the heating function.

## FRANÇAIS

Impressionnante cheminée électrique à encastrer ou à poser modèle Etna, 300 cm de long, effet de flamme réalisé par LED et réglable en intensité. Deux paliers de puissance 750-1500W. Peut être contrôlé manuellement ou avec la télécommande incluse. Possibilité d'utiliser uniquement l'effet de flamme sans la fonction de chauffage.

## DEUTSCH

Beeindruckender Einbau- oder freistehender Elektrokamin Modell Etna, 300 cm lang, Flammeneffekt durch LED realisiert und in der Intensität einstellbar. Zwei Leistungsstufen 750-1500W. Kann manuell oder mit der mitgelieferten Fernbedienung gesteuert werden. Es besteht die Möglichkeit, nur den Flammeneffekt ohne Heizfunktion zu nutzen.



**DIMENSIONI**  
50,7x20x300 CM

**PESO**  
63 KG

**COLORE**  
nero

**TIPO DI CALORE**  
termoconvettore  
750-1500W

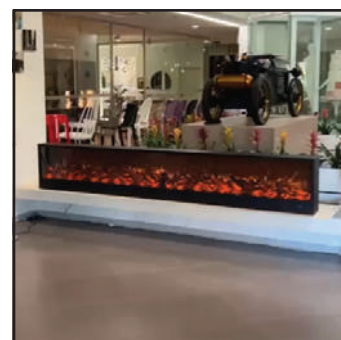

**Unici modelli in europa certificati e testati per incasso completo**  
EU directives compliance  
LVD 2014/35/UE  
EMC 2014/30/UE  
DERP 2009/125/CE  
RoHS 2011/65/EU ((UE) 2015/863)

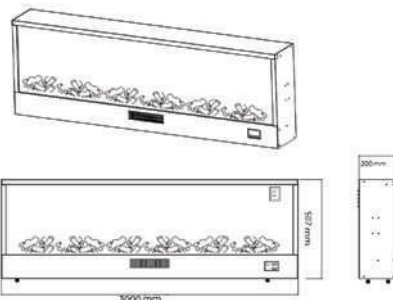





## CAMINETTI DA PARETE

*SI APPENDONO ALLA PARETE COME UN QUADRO!*

Unici modelli in Europa con certificazioni di risparmio energetico ERP2009/125/CE. Funzionano in base alla temperatura reale, grazie al sensore di temperatura e al termostato e al programmatore settimanale. Conformità alle direttive UE aggiornate verificata da una società di certificazione esterna Europea.

## WALL FIREPLACES

*HANGS ON THE WALL LIKE A PAINTING*

The only models in Europe with ERP2009/125/EC energy-saving certifications.

They operate according to actual temperature, thanks to the temperature sensor and thermostat and weekly programmer. Compliance with updated EU directives verified by an external European certification company.

## CHEMINÉES MURALES

*S'ACCROCHE AU MUR COMME UN TABLEAU*

Les seuls modèles en Europe avec les certifications d'économie d'énergie ERP2009/125/EC.

Fonctionne en fonction de la température réelle, grâce à la sonde de température, au thermostat et au programmeur hebdomadaire. Conformité aux directives européennes mises à jour, certifiée par une société de certification européenne externe.

## CHIMENEAS DE PARED

*CUELGA DE LA PARED COMO UN CUADRO*

Los únicos modelos en Europa con certificaciones de ahorro energético ERP2009/125/CE.

Funcionan en función de la temperatura real, gracias al sensor de temperatura y termostato y programador semanal. Cumplimiento de las directivas actualizadas de la UE verificadas por una empresa de certificación europea externa.

## WANDKAMINE

*HÄNGT AN DER WAND WIE EIN GEMÄLDE*

Die einzigen Modelle in Europa mit ERP2009/125/EG-Energiesparzertifikat.

Betrieb nach der tatsächlichen Temperatur, dank Temperatursensor und Thermostat und Wochenprogrammierer. Die Einhaltung der aktualisierten EU-Richtlinien wurde von einem externen europäischen Zertifizierungsunternehmen zertifiziert.



# CAMINETTO-PARETE-MONTE-BIANCO

8025431019225

## 98 cm



### DOPPIA MODALITA' DI FUNZIONAMENTO

solo effetto fiamma ultra realistico o riscaldante con motore PCT da 1500w sigillato ermeticamente. Vetro cristallo temperato. Pannello di controllo LCD frontale. Comandi manuali laterali, uscita e ingresso dell'aria sono posizionati nella parte superiore. Il caminetto è imballato in una scatola di cartone rinforzato.

**ATTENZIONE!** I caminetti da parete sono progettati per essere appesi alla parete. Non devono essere installati/incassati all'interno.

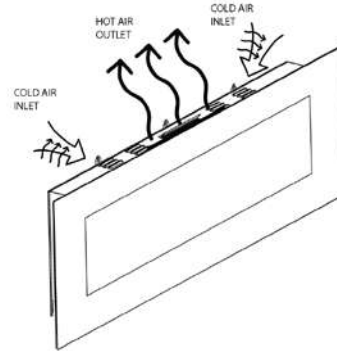

### ITALIANO

Caminetto elettrico da parete modello Monte Bianco in acciaio e vetro. Potenza massima riscaldante 1500W. Realistico effetto fiamma LED regolabile in 6 livelli di intensità della luce Telecomando a infrarossi incluso. Ottimo per casa e ufficio. Comandabile dal telecomando o dal display sul pannello di comando laterale.

### ESPAÑOL

Chimenea eléctrica de pared modelo Mont Blanc en acero y cristal. Potencia máxima de calentamiento 1500W. Efecto de llama LED realista ajustable en 6 niveles de intensidad luminosa Mando a distancia por infrarrojos incluido. Ideal para el hogar y la oficina. Se puede controlar desde el mando a distancia o la pantalla del panel de control lateral.

### ENGLISH

Wall-mounted electric fireplace model Mont Blanc in steel and glass. Maximum heating power 1500W. Realistic LED flame effect adjustable in 6 light intensity levels Infrared remote control included. Great for home and office. Controllable from the remote control or the display on the side control panel.

### FRANÇAIS

Cheminée électrique murale modèle Mont Blanc en acier et verre. Puissance de chauffage maximale de 1500W. Effet de flamme LED réaliste réglable sur 6 niveaux d'intensité lumineuse Télécommande infrarouge incluse. Idéal pour la maison et le bureau. Contrôlable à partir de la télécommande ou de l'écran du panneau de commande latéral.

### DEUTSCH

Elektrischer Wandkamin Modell Mont Blanc aus Stahl und Glas. Maximale Heizleistung 1500W. Realistischer LED-Flammeneffekt in 6 Helligkeitsstufen einstellbar Infrarot-Fernbedienung inklusive. Ideal für Haus und Büro. Die Steuerung erfolgt über die Fernbedienung oder das Display am seitlichen Bedienfeld.



### DIMENSIONI

98x55x14 CM

### PESO

15,6 KG

### COLORE

bianco

### TIPO DI CALORE

termoconvettore

750-1500W



**Unici modelli in europa certificati e testati**

*EU directives compliance*

*LVD 2014/35/UE*

*EMC 2014/30/UE*

*DERP 2009/125/CE*

*RoHS 2011/65/EU ((UE) 2015/863)*

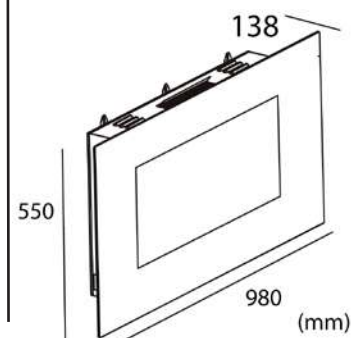

# CAMINETTO-PARETE-STELVIO

8025431019232



## 128 cm



### DOPPIA MODALITA' DI FUNZIONAMENTO

solo effetto fiamma ultra realistico o riscaldante con motore PCT da 1500w sigillato ermeticamente. Vetro cristallo temperato. Pannello di controllo LCD frontale. Comandi manuali laterali, uscita e ingresso dell'aria sono posizionati nella parte superiore. Il caminetto è imballato in una scatola di cartone rinforzato.

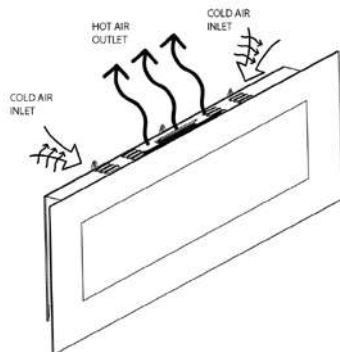

**ATTENZIONE!** I caminetti da parete sono progettati per essere appesi alla parete. Non devono essere installati/incassati all'interno.

### ITALIANO

Caminetto elettrico da parete modello Stelvio in acciaio e vetro. Potenza massima riscaldante 1500W. Realistico effetto fiamma LED regolabile in 6 livelli di intensità luce Telecomando incluso. Ottimo per casa ufficio, attività commerciali.  
Comandabile dal telecomando o dal display sul pannello di comando laterale.

### ESPAÑOL

Chimenea eléctrica de pared modelo Stelvio en acero y cristal. Potencia máxima de calentamiento 1500W. Efecto de llama LED realista ajustable en 6 niveles de intensidad de luz Mando a distancia incluido. Ideal para la oficina en casa, el negocio.  
Se puede controlar desde el mando a distancia o la pantalla del panel de control lateral.

### ENGLISH

Wall-mounted electric fireplace model Stelvio in steel and glass. Maximum heating power 1500W. Realistic LED flame effect adjustable in 6 light intensity levels Remote control included. Great for home office, business.  
Controllable from the remote control or the display on the side control panel.

### FRANÇAIS

Cheminée électrique murale modèle Stelvio en acier et verre. Puissance de chauffage maximale de 1500W. Effet de flamme LED réaliste réglable en 6 niveaux d'intensité lumineuse Télécommande incluse. Idéal pour le bureau à domicile, les affaires.  
Contrôlable à partir de la télécommande ou de l'écran du panneau de commande latéral.

### DEUTSCH

Elektrischer Wandkamin Modell Stelvio aus Stahl und Glas. Maximale Heizleistung 1500W. Realistischer LED-Flammeneffekt, der in 6 Helligkeitsstufen einstellbar ist, inklusive Fernbedienung. Ideal für Heimbüro, Geschäft.  
Die Steuerung erfolgt über die Fernbedienung oder das Display am seitlichen Bedienfeld.



### DIMENSIONI

128x55x14 CM

### PESO

20,6 KG

### COLORE

nero

### TIPO DI CALORE

termoconvettore

750-1500W

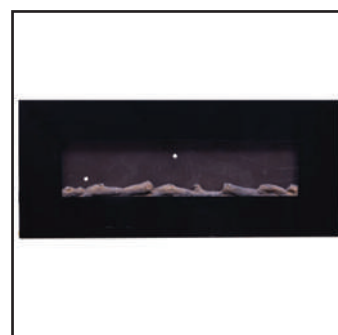
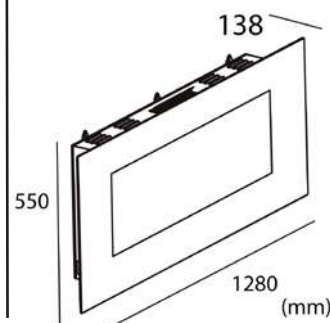

**Unici modelli in europa  
certificati e testati**

*EU directives compliance*

*LVD 2014/35/UE*

*EMC 2014/30/UE*

*DERP 2009/125/CE*

*RoHS 2011/65/EU ((UE) 2015/863)*

# CAMINETTO-PARETE-APRICA

8025431019249



## DOPPIA MODALITA' DI FUNZIONAMENTO

solo effetto fiamma ultra realistico o riscaldante con motore PCT da 1500w sigillato ermeticamente. Vetro cristallo temperato. Pannello di controllo LCD frontale. Comandi manuali laterali, uscita e ingresso dell'aria sono posizionati nella parte superiore. Il caminetto è imballato in una scatola di cartone rinforzato.

**ATTENZIONE!** I caminetti da parete sono progettati per essere appesi alla parete. Non devono essere installati/incassati all'interno.

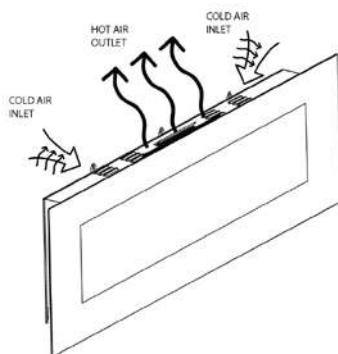

## ITALIANO

Caminetto elettrico da parete modello Aprica in acciaio e vetro. Potenza massima riscaldante 1500W. Realistico effetto fiamma LED regolabile in 6 livelli di intensità della luce Telecomando a infrarossi incluso. Ottimo per casa e ufficio. Comandabile dal telecomando o dal display sul pannello di comando laterale.

## FRANÇAIS

Cheminée électrique murale modèle Aprica en acier et verre. Puissance de chauffage maximale de 1500W. Effet de flamme LED réaliste réglable sur 6 niveaux d'intensité lumineuse Télécommande infrarouge incluse. Idéal pour la maison et le bureau. Contrôlable à partir de la télécommande ou de l'écran du panneau de commande latéral.

## ESPAÑOL

Chimenea eléctrica de pared modelo Aprica de acero y cristal. Potencia máxima de calentamiento 1500W. Efecto de llama LED realista ajustable en 6 niveles de intensidad luminosa Mando a distancia por infrarrojos incluido. Ideal para el hogar y la oficina. Se puede controlar desde el mando a distancia o la pantalla del panel de control lateral.

## DEUTSCH

Elektrischer Wandkamin Modell Aprica aus Stahl und Glas. Maximale Heizleistung 1500W. Realistischer LED-Flammeneffekt in 6 Helligkeitsstufen einstellbar Infrarot-Fernbedienung inklusive. Ideal für Haus und Büro. Die Steuerung erfolgt über die Fernbedienung oder das Display am seitlichen Bedienfeld.

## ENGLISH

Aprica model wall-mounted electric fireplace in steel and glass. Maximum heating power 1500W. Realistic LED flame effect adjustable in 6 light intensity levels Infrared remote control included. Great for home and office. Controllable from the remote control or the display on the side control panel.



## DIMENSIONI

152x55x13,8 CM

## PESO

24,1 KG

## COLORE

nero

## TIPO DI CALORE

termoconvettore

750-1500W

# 152 cm



**Unici modelli in europa  
certificati e testati**

*EU directives compliance*

LVD 2014/35/UE

EMC 2014/30/UE

DERP 2009/125/CE

RoHS 2011/65/EU ((UE) 2015/863)

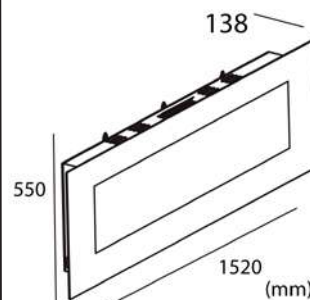



# CAMINETTO-PARETE-PORDOI

8025431019256

## 183 cm

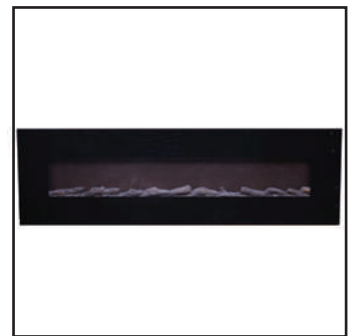

**DOPPIA MODALITA' DI FUNZIONAMENTO**  
 solo effetto fiamma ultra realistico o riscaldante con motore PCT da 1500w sigillato ermeticamente. Vetro cristallo temperato. Pannello di controllo LCD frontale. Comandi manuali laterali, uscita e ingresso dell'aria sono posizionati nella parte superiore. Il caminetto è imballato in una scatola di cartone rinforzato.

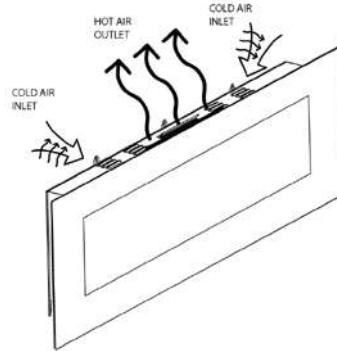

**ATTENZIONE!** I caminetti da parete sono progettati per essere appesi alla parete. Non devono essere installati/incassati all'interno.

### ITALIANO

Caminetto elettrico nero da parete modello Pordoi in acciaio e vetro. Potenza massima riscaldante 1500W. Realistico effetto fiamma LED regolabile in 6 livelli di intensità della luce Telecomando a infrarossi incluso. Ottimo per casa e ufficio. Comandabile dal telecomando o dal display sul pannello di comando laterale.

### ESPAÑOL

Chimenea eléctrica de pared negra modelo Pordoi de acero y cristal. Potencia máxima de calentamiento 1500W. Efecto de llama LED realista ajustable en 6 niveles de intensidad luminosa Mando a distancia por infrarrojos incluido. Ideal para el hogar y la oficina. Se puede controlar desde el mando a distancia o la pantalla del panel de control lateral.

### ENGLISH

Black electric wall-mounted fireplace model Pordoi in steel and glass. Maximum heating power 1500W. Realistic LED flame effect adjustable in 6 light intensity levels Infrared remote control included. Great for home and office. Controllable from the remote control or the display on the side control panel.

### FRANÇAIS

Cheminée électrique murale noire modèle Pordoi en acier et verre. Puissance de chauffage maximale de 1500W. Effet de flamme LED réaliste réglable sur 6 niveaux d'intensité lumineuse Télécommande infrarouge incluse. Idéal pour la maison et le bureau. Contrôlable à partir de la télécommande ou de l'écran du panneau de commande latéral.

### DEUTSCH

Schwarzer elektrischer Wandkamin Modell Pordoi aus Stahl und Glas. Maximale Heizleistung 1500W. Realistischer LED-Flammeneffekt in 6 Helligkeitsstufen einstellbar Infrarot-Fernbedienung inklusive. Ideal für Haus und Büro. Die Steuerung erfolgt über die Fernbedienung oder das Display am seitlichen Bedienfeld.



### DIMENSIONI

182,5x55x13,9 CM

### PESO

29,5 KG

### COLORE

nero

### TIPO DI CALORE

termoconvettore

750-1500W

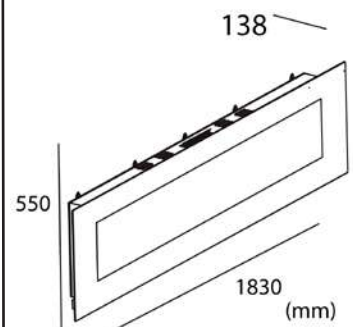

**Unici modelli in europa  
 certificati e testati**

*EU directives compliance*

*LVD 2014/35/UE*

*EMC 2014/30/UE*

*DERP 2009/125/CE*

*RoHS 2011/65/EU ((UE) 2015/863)*



## **RISCALDATORI A INFRAROSSI A ONDE CORTE O ONDE LUNGHE**

*IDEALI PER ESTERNI, TERRAZZE, PATII...*

**SHORT AND LONG WAVE  
INFRARED HEATERS**

*IDEAL FOR EXTERIORS, TERRACES, PATIOS...*

**CHAUFFAGES INFRAROUGES  
À ONDES COURTES OU  
À ONDES LONGUES**

*IDÉAL POUR LES EXTÉRIEURS, TERRASSES, PATIOS...*

**CALEFACTORES INFRARROJOS  
DE ONDA CORTA O LARGA**

*IDEALES PARA EXTERIORES, TERRAZAS, PATIOS...*

**INFRAROTHEIZUNGEN  
KURZWELLIG ODER  
LANGWELLIG**

*IDEAL FÜR AUSSENBEREICHE, TERRASSEN, INNENHÖFE...*

# CALDO-VETRO-NERO-2000

8025431012233

# CALDO-VETRO-NERO-2000-WIFI

8025431018846



**VETRO BLACK SCHOTT**  
RIDUCE L'EMISSIONE DI  
LUCE E RADIAZIONI  
NOCIVE.

LAMPADA RISCALDANTE  
**LOW GLARING**



**CALDO-VETRO-NERO-2000-WIFI **  
CONTROLLO TRAMITE SMARTPHONE  
SOLO MODELLO WIFI

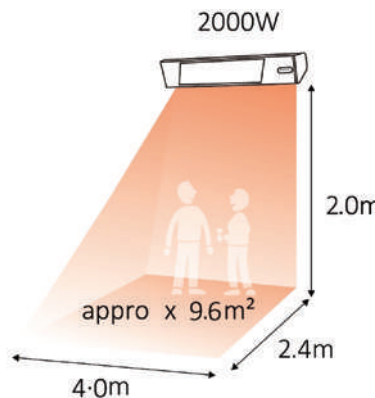

## ITALIANO

Riscaldatore infrarossi con vetro in ceramica brevettato Black Schott. Questo vetro è particolarmente adatta per esterno grazie alla sua resistenza al calore e agli shock termici, alle corrosioni e alle intemperie. Riduce inoltre l'abbagliamento luminoso che può essere un problema pericoloso e fastidioso.

## ESPAÑOL

Calentador de infrarrojos especial y moderno optimizado para bares y terrazas con una potencia regulable de 2000W. La estructura es de acero y aluminio resistente a la corrosión. El grado de protección del calentador infrarrojo de área comercial es IP65 lo que hace que este producto sea adecuado para todos los climas.

## ENGLISH

Infrared heater with patented Black Schott ceramic glass. This glass is particularly suitable for outdoors due to its resistance to heat and thermal shock, corrosion and weathering. It also reduces light glare, which can be a dangerous and annoying problem.

## FRANÇAIS

Réchauffeur infrarouge avec verre céramique Black Schott breveté. Ce verre est particulièrement adapté à l'extérieur en raison de sa résistance à la chaleur et aux chocs thermiques, à la corrosion et aux intempéries. Il réduit également l'éblouissement, qui peut être un problème dangereux et gênant.

## DEUTSCH

Infrarotheizung mit patentiertem Black Schott Keramikglas. Dieses Glas ist aufgrund seiner Hitze- und Temperaturwechselbeständigkeit, seiner Korrosions- und Witterungsbeständigkeit besonders für den Außenbereich geeignet. Außerdem wird die Blendung durch Licht reduziert, die ein gefährliches und lästiges Problem darstellen kann.

## DIMENSIONI

13,9x11x74,2 CM

## PESO

3,2 KG

## COLORE

Nero

**TIPO DI CALORE**  
onda corta IR-A

## ONDA CORTA



## WEATHERPROOF





# CALDO-VETRO-NERO-PIEDISTALLO

8025431016620

# CALDO-VETRO-NERO-PIEDISTALLO-WIFI

8025431018853



## CALDO-VETRO-NERO-PIEDISTALLO-WIFI

CONTROLLO TRAMITE SMARTPHONE  
SOLO MODELLO WIFI

**VETRO BLACK  
SCHOTT**  
RIDUCE L'EMISSIONE  
DI LUCE E RADIAZIONI  
NOCIVE.

**LAMPADA  
RISCALDANTE  
LOW GLARING**



### ITALIANO

Radiatore a infrarossi per esterni dalla potenza di 2000W con piedistallo a onda corta IR-A, il nostro prodotto può raggiungere la potenza massima in meno di 8 secondi.

Realizzato con materiale di alta qualità acciaio inox, alluminio anodizzato e vetroceramico, per questo è stato classificato come grado di protezione IP65.

### FRANÇAIS

Réchauffeur infrarouge extérieur d'une puissance de 2000W avec piédestal IR-A à ondes courtes, notre produit peut atteindre la puissance maximale en moins de 8 secondes.

Est fait de matériaux de haute qualité en acier inoxydable, aluminium anodisé et verre céramique, c'est pourquoi il est classé comme protection IP65.

### ESPAÑOL

Calentador de infrarrojos para exteriores de 2000W con pedestal IR-A de onda corta. Puede alcanzar la máxima potencia en menos de 8 seg.

Hecho de acero inoxidable, aluminio anodizado y con superficie calentadora patentada en Cristal Negro, por eso está clasificado como grado de protección IP65.

### DEUTSCH

Infrarot-Heizung mit Standfuss für den Außenbereich mit einer Leistung von 2000W. Kurzwellen IR-A Heizung, womit die maximale Leistung in weniger als 8sek. erreicht werden kann.

Ist aus hochwertigem Material Edelstahl, eloxiertem Aluminium und Keramikglas hergestellt und kann dank Schutzklasse IP65 auch in im Garten oder auf der Terrasse aufgestellt werden.

### ENGLISH

Outdoor infrared heater with 2000W power with IR-A short wave pedestal, our product can reach maximum power in less than 8 seconds.

Our infrared heat is made of high quality material stainless steel, anodized aluminum and glass ceramic, so it is classified as IP65 protection grade.

### DIMENSIONI

218X74.2X11 CM

### PESO

21,2 KG

### COLORE

Argento

**TIPO DI CALORE**  
onda corta IR-A

## ONDA CORTA



## WEATHERPROOF



IP65 protection



218 cm

60 cm







# STUFA-INFRAROSSO-PARETE-2000

8025431012295



## LAMPADA RISCALDANTE LOW GLARING

### ITALIANO

Pratico ed economico riscaldatore con palpebra riflettente da parete con telecomando, ottimo anche come diffusore di calore a parete. Potenza totale 2000 W. Protetto contro i getti d'acqua con IP55.

Il riscaldatore ha incorporata la funzione timer per lo spegnimento, impostabile da 1 a 13 ore.

### FRANÇAIS

Réchauffeur réflecteur mural pratique et économique avec télécommande, également excellent comme diffuseur de chaleur mural. Puissance totale 2000 W. Protégé contre les jets d'eau avec IP55.

L'appareil de chauffage dispose d'une fonction minuterie d'arrêt intégrée qui peut être réglée de 1 à 13 heures.

### ESPAÑOL

Práctico y económico calentador reflector de infrarrojos con control remoto, también excelente como difusor de calor de pared. Potencia total 2000 W. Protegido contra los chorros de agua con IP55.

El calentador tiene una función de temporizador de apagado incorporado que puede ser ajustado de 1 a 13 horas.

### DEUTSCH

Praktischer und wirtschaftlicher Wand-Reflektor-Heizstrahler mit Fernbedienung, der sich auch hervorragend als Wand-Wärmeverteiler eignet. Gesamtleistung 2000 W. Geschützt gegen Strahlwasser mit IP65.

Das Heizgerät hat eine eingebaute Abschalt-Timer-Funktion, die von 1 bis 13 Stunden eingestellt werden kann.

### ENGLISH

Practical and economical wall-mounted reflector heater with remote control, also excellent as a wall-mounted heat diffuser. Total power 2000 W. Protected against water jets with IP55.

The heater has a built-in switch-off timer function that can be set from 1 to 13 hours.

### DIMENSIONI

64x19x41 CM

### PESO

3,8 KG

### COLORE

Grigio

### TIPO DI CALORE onda corta IR-A

## ONDA CORTA



### Infrared waves





**ONDA CORTA**

LAMPADA RISCALDANTE  
LOW GLARING



## STUFA-INFRAROSSI-TERRA-2000

8025431012288



### ITALIANO

Riscaldatore palpebra riflettente da terra su piantana  
Riscaldatore con palpebra riflettente orientabile da parete con telecomando, ottimo anche come diffusore di calore a parete. Potenza totale 2000 W. Protetto contro i getti d'acqua con IP55. Il cavo elettrico risulta nascosto all'interno dell'asta

### FRANÇAIS

Chauffe-paupières réfléchissant sur pied  
Chauffe-paupières réfléchissant mural réglable avec télécommande, également excellent comme diffuseur de chaleur mural. Puissance totale 2000 W. Protégé contre les jets d'eau avec IP55. Le câble électrique est dissimulé à l'intérieur du poteau.

### ESPAÑOL

Calentador de infrarrojos con parábola reflectante, instalación de pie o de pared.  
Calentador de pared ajustable con control remoto, también llega con base para el montaje independiente, garantizando la movilidad y la versatilidad. Potencia 2000 W. Protegido contra los chorros de agua con IP55. El cable eléctrico está oculto dentro del poste.

### DEUTSCH

Bodenstehender reflektierender Heizstrahler, auch als Außenheizung geeignet.  
Terrassenheizer mit inklusiver Fernbedienung. Gesamtleistung 2000 W. Geschützt gegen Strahlwasser mit IP65. Das Stromkabel ist im Inneren des Ständers versteckt

### ENGLISH

Floor standing reflective eyelid heater  
Adjustable wall mounted reflective eyelid heater with remote control, also excellent as a wall mounted heat diffuser. Total power 2000 W. Protected against water jets with IP55. The electric cable is hidden inside the pole

### DIMENSIONI

218x60x60 CM

### PESO

21,5 KG

### COLORE

grigio

### TIPO DI CALORE

onda corta IR-A





# STUFA-INFRAROSSO-SOFFITTO-4000

8025431015562



## LAMPADA RISCALDANTE LOW GLARING

### ITALIANO

Doppio riscaldatore riflettente da soffitto con palpebra da 2000W l'uno da un totale di 4000W realizzate in acciaio inox e alluminio anodizzato di altissima qualità.

Riscaldatore riflettente da soffitto a onda corta IR-A, il dispositivo arriva alla sua potenza massima in meno 8 secondi.

### FRANÇAIS

Double radiateur de plafond réfléchissant de 2000W chacun avec un total de 4000W fabriqué en acier inoxydable de la plus haute qualité et en aluminium anodisé.

L'IR à ondes courtes - un chauffage de plafond réfléchissant, l'appareil atteint sa puissance maximale en moins de 8 secondes.

### ESPAÑOL

Calentador de techo doble de 2000W cada uno con un total de 4000W fabricado en acero inoxidable y aluminio anodizado de la más alta calidad. Diseño especial con parábola reflectante para maximizar la eficiencia de la calefacción.

Calentador de techo IR-A de onda corta, el dispositivo alcanza su máxima potencia en menos de 8 segundos

### DEUTSCH

Doppelte reflektierende Deckenheizung mit je 2000W Gesamtleistung 4000W aus hochwertigem Edelstahl und eloxiertem Aluminium.

Der IR-A-Deckenstrahler erreicht seine maximale Leistung in weniger als 8 Sekunden.

### ENGLISH

Double reflective ceiling heater with 2000W each with a total of 4000W made of stainless steel and anodized aluminum of the highest quality.

Short wave IR-A reflective ceiling heater, the device reaches its maximum power in less than 8 seconds.

### DIMENSIONI

40x60x74 CM

### PESO

10 KG

### COLORE

Grigio

### TIPO DI CALORE onda corta IR-A

## ONDA CORTA





# CALORE-BIANCO

CALORE-BIANCO-1500 / 8025431012240

CALORE-BIANCO-1800 / 8025431012257

CALORE-BIANCO-2400 / 8025431012264

CALORE-BIANCO-3200 / 8025431012271



Indoor spot heating

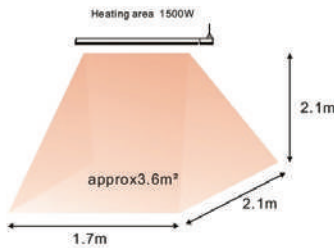

Outdoor enclosed area

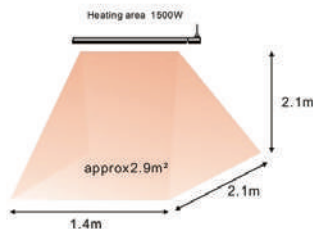

EMETTE SOLO LA PARTE MIGLIORE DEL CALORE DEL SOLE, CHE È BENEFICO PER LA SALUTE.

## ITALIANO

Lo speciale elemento riscaldante in alluminio trasforma il 99% dell'energia elettrica in calore.

Il risparmio energetico è dato dal fatto che questi riscaldatori infrarossi riscaldano direttamente le persone, non tutto l'ambiente come i riscaldatori tradizionali. Radiatore a infrarossi per esterni serie A7 IR-C, infrarosso lontano con nessuna emissione di luce.

## FRANÇAIS

Chauffage infrarouge extérieur série A7 IR-C, infrarouge lointain sans émission de lumière. En alliage d'aluminium extrudé avec revêtement céramique infrarouge. Adapté au montage au plafond et au mur. Étanche à l'eau : IP65, convient à la poussière et à la pluie à l'extérieur. Meilleures performances dans les zones extérieures ou intérieures très abritées et sans vent, comme les jardins d'hiver.

## ESPAÑOL

Calentador de infrarrojo exterior serie A7 IR-C, de onda larga sin emisión de luz. De aleación de aluminio con pintura cerámica. Se incluye soporte inox. para montaje en techo o pared. A prueba de agua: IP65, apto para polvo y la lluvia en exterior. El mejor rendimiento es áreas exteriores o interiores protegidas de viento, como invernaderos.

## DEUTSCH

Außen-Infrarotstrahler IR-C Langwellen Infrarot-Heizung ohne Lichtemission. Heizelement aus Aluminiumlegierung, Gehäuse mit Keramikbeschichtung Farbe Weiss. Inklusive Edelstahlhalterung, geeignet für Decken- und Wandmontage. Wasserdicht: IP65, geeignet für Staub und Regen im Freien. Beste Leistung in sehr geschützten und windstillen Außen- oder Innenbereichen.

## ENGLISH

Outdoor infrared heater series A7 IR-C, far infrared with no light emission. Extruded aluminum alloy heating element with ceramic infrared paint. Stainless steel bracket included, suitable for ceiling and wall mounting. Water proof: IP65, suitable for dust and rain outdoors. Best performance in very sheltered and windless outdoor or indoor areas, such as winter gardens.

## DIMENSIONI

104,5-191,5x17,7x6 CM

## PESO

5,4/6,1/7,5/9,5 KG

## COLORE

bianco

TIPO DI CALORE  
onde lunghe A7 IR-C

## ONDA LUNGA



## WEATHERPROOF



IP65 protection



104,5 cm (1500W)  
122,5 cm (1800W)  
150,5 cm (2400W)  
191,5 cm (3200W)



# CALORE-NERO

CALORE-NERO-1500 / 8025431016521

CALORE-NERO-1800 / 8025431016538

CALORE-NERO-2400 / 8025431016545

CALORE-NERO-3200 / 8025431016552



Indoor spot heating

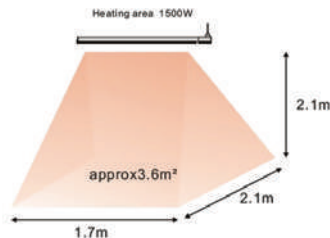

Outdoor enclosed area

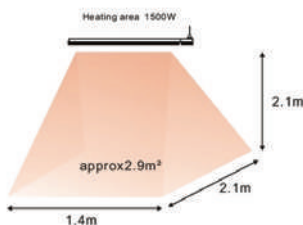

EMETTE SOLO LA PARTE MIGLIORE DEL CALORE DEL SOLE, CHE È BENEFICO PER LA SALUTE.

## ITALIANO

Lo speciale elemento riscaldante in alluminio trasforma il 99% dell'energia elettrica in calore. Il risparmio energetico è dato dal fatto che questi riscaldatori infrarossi riscaldano direttamente le persone, non tutto l'ambiente come i riscaldatori tradizionali. Radiatore a infrarossi per esterni serie A7 IR-C, infrarosso lontano con nessuna emissione di luce.

## FRANÇAIS

Chauffage infrarouge extérieur série A7 IR-C, infrarouge lointain sans émission de lumière. En alliage d'aluminium extrudé avec revêtement céramique infrarouge. Adapté au montage au plafond et au mur. Étanche à l'eau : IP65, convient à la poussière et à la pluie à l'extérieur. Meilleures performances dans les zones extérieures ou intérieures très abritées et sans vent, comme les jardins d'hiver.

## ESPAÑOL

Calentador de infrarrojo exterior serie A7 IR-C, de onda larga sin emisión de luz. De aleación de aluminio con pintura cerámica. Se incluye soporte inox. para montaje en techo o pared. A prueba de agua: IP65, apto para polvo y la lluvia en exterior. El mejor rendimiento es áreas exteriores o interiores protegidas de viento, como invernaderos.

## DEUTSCH

Außen-Infrarotstrahler IR-C Langwellen Infrarot-Heizung ohne Lichtemission. Heizelement aus Aluminiumlegierung, Gehäuse mit Keramikbeschichtung Farbe Weiss. Inklusive Edelstahlhalterung, geeignet für Decken- und Wandmontage. Wasserdicht: IP65, geeignet für Staub und Regen im Freien. Beste Leistung in sehr geschützten und windstillen Außen- oder Innenbereichen.

## ENGLISH

Outdoor infrared heater series A7 IR-C, far infrared with no light emission. Extruded aluminum alloy heating element with ceramic infrared paint. Stainless steel bracket included, suitable for ceiling and wall mounting. Water proof: IP65, suitable for dust and rain outdoors. Best performance in very sheltered and windless outdoor or indoor areas, such as winter gardens.

## DIMENSIONI

104,5-191,5x17,7x6 CM

## PESO

5,4/6,1/7,5/9,5 KG

## COLORE

nero

TIPO DI CALORE onde lunghe A7 IR-C

## ONDA LUNGA

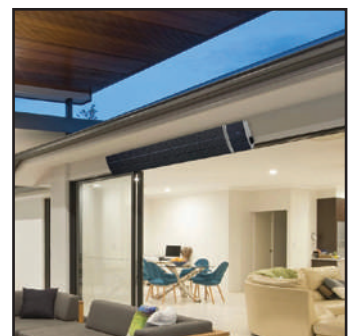

104,5 cm (1500W)  
122,5 cm (1800W)  
150,5 cm (2400W)  
191,5 cm (3200W)



# CALORE-NERO

CALORE-NERO-1500-WIFI / 8025431018907

CALORE-NERO-1800-WIFI / 8025431018914

CALORE-NERO-2400-WIFI / 8025431018921

CALORE-NERO-3200-WIFI / 8025431018938



Indoor spot heating

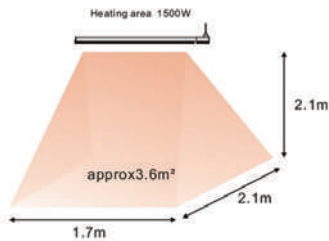

Outdoor enclosed area

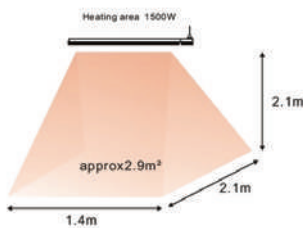

CONTROL VIA SMARTPHONE



EMETTE SOLO LA PARTE MIGLIORE DEL CALORE DEL SOLE, CHE È BENEFICO PER LA SALUTE.

## ITALIANO

Radiatore WIFI a infrarossi per esterni serie A7 IR-C , infrarosso lontano con nessuna emissione di luce. Elemento riscaldante in lega di alluminio estruso con verniciatura a infrarossi in ceramica. Staffa in acciaio inossidabile inclusa, adatta per il montaggio a soffitto e a parete.

## ESPAÑOL

Radiador infrarrojo para exteriores WIFI serie A7 IR-C , infrarrojo lejano sin emisión de luz. Elemento calefactor de aleación de aluminio extruido con revestimiento cerámico de infrarrojos. Soporte de acero inoxidable incluido, adecuado para el montaje en el techo y en la pared.

## ENGLISH

WIFI infrared outdoor radiator series A7 IR-C , far infrared with no light emission. Heating element made of extruded aluminium alloy with ceramic infrared coating. Stainless steel bracket included, suitable for ceiling and wall mounting.

## FRANÇAIS

Radiateur extérieur infrarouge WIFI série A7 IR-C, infrarouge lointain sans émission de lumière. Élément chauffant en alliage d'aluminium extrudé avec revêtement céramique infrarouge. Support en acier inoxydable inclus, adapté au montage au plafond et au mur.

## DEUTSCH

WIFI-Infrarotstrahler für den Außenbereich Serie A7 IR-C, Ferninfrarot ohne Lichtemission. Heizelement aus einer stranggepressten Aluminiumlegierung mit keramischer Infrarotbeschichtung. Inklusive Edelstahlhalterung, geeignet für Decken- und Wandmontage.

## DIMENSIONI

104,5-191.5x17,7x6 CM

## PESO

5,4/6,1/7,5/9,5 KG

## COLORE

nero

TIPO DI CALORE  
onde lunghe A7 IR-C

## ONDA LUNGA



104,5 cm (1500W)  
122,5 cm (1800W)  
150,5 cm (2400W)  
191,5 cm (3200W)



# Riscaldatore Infrarossi 4000 INDUSTRIAL-MPC

8025431054783

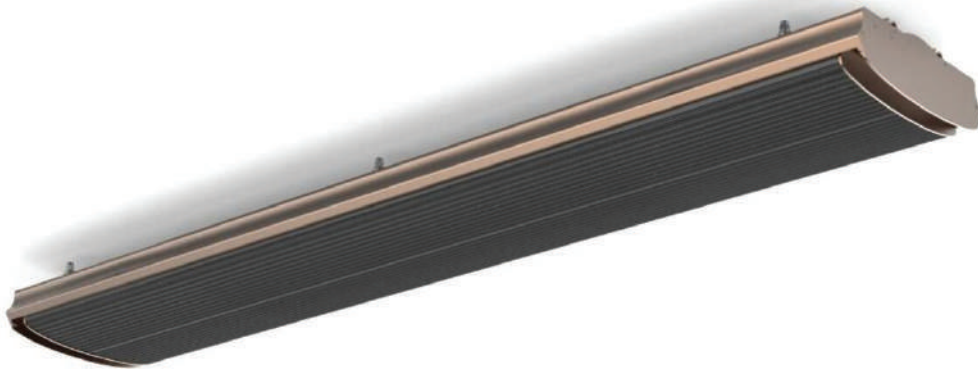

**ONDA LUNGA**

**TRIFASE 380V**



**Infrared waves**



**DESTINATO ALL'USO INDUSTRIALE**  
**ALIMENTAZIONE: 380V 50-60 Hz**  
**RISPARMIA ELETTRICITÀ E DENARO**

**ITALIANO**

Pannello infrarossi industriale Riscaldatore ad infrarossi da 4000 Watt di potenza Classe di protezione IPX4 e sistema di protezione contro il surriscaldamento Area coperta dal riscaldamento 50 mq Installazione a muro o parete. Durante l'utilizzo di questo prodotto non verranno generati vento, luci o odori, e l'aria interna rimarrà pulita e priva di polveri.

**FRANÇAIS**

Panneau infrarouge industriel Réchauffeur avec une puissance de 4000 Watt Classe de protection IPX4 et système de protection contre la surchauffe Surface couverte par le réchauffeur 50 m<sup>2</sup> Installation murale ou au mur.

La température interne peut être réglée librement, quelle que soit la température extérieure saisonnière.

**ESPAÑOL**

Panel industrial de infrarrojos Calentador con 4000 vatios de potencia Clase de protección IPX4 y sistema de protección contra el sobrecalentamiento Superficie cubierta por el calentador 50 m<sup>2</sup> Instalación en la pared o en el muro.

No se generará viento, luz u olor al utilizar este producto, y el aire interior permanecerá limpio y sin polvo.

**DEUTSCH**

Industrielles Infrarotpaneel Infrarotheizung mit 4000 Watt Leistung Schutzklasse IPX4 und Überhitzungsschutzsystem Flächenabdeckung der Heizung 50 m<sup>2</sup> Wand- oder Wandmontage.

Bei der Verwendung dieses Produkts entstehen kein Wind, kein Licht und kein Geruch, und bleibt die Raumluft sauber und staubfrei.

**ENGLISH**

Industrial infrared panel Heater with 4000 Watt power IPX4 protection class and overheating protection system Area covered by heater 50 m<sup>2</sup> Wall or wall installation.

No wind, light or odour will be generated when using this product, and the indoor air will remain clean and dust-free.

**DIMENSIONI**

200x18,9x6,7 CM

**PESO**

11,4 KG

**COLORE**

nero

**TIPO DI CALORE**  
onde lunghe A7 IR-C

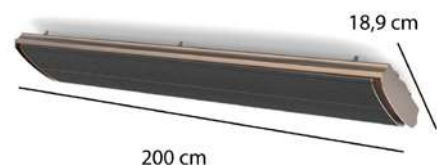



# Riscaldatore da Pavimento 1800-MPC

Riscaldatore da Pavimento 1800-MPC / 8025431058538

Riscaldatore da Pavimento 2000-MPC / 8025431058545

Riscaldatore da Pavimento 2200-MPC / 8025431058552



## TERMO CONVETTORE SENZA VENTOLE



### Lastest technology

Get rid of bad performances, such as glare, high energy consumption, dry, noise, operating space, and difficult in manipulation, etc.

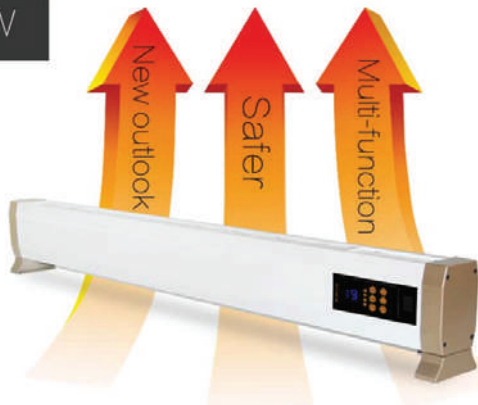

**NON FA POLVERE**

**ULTRA SILENZIOSO**

#### ITALIANO

Pratica stufa per pavimento e battiscopa con una potenza da 1800W a 2200W. Design moderno ed elegante che ben si addice per un uso sia privato che pubblico. Anche se molto efficiente questo termoconvettore elettrico è poco più alto di un battiscopa e ben si abbina a tutti i locali di casa.

#### ESPAÑOL

Práctico calefactor de suelo y zócalo con una potencia de 1800W a 2200W. Diseño moderno y elegante que se adapta tanto al uso privado como al público. Aunque muy eficiente, este convector eléctrico es un poco más alto que un rodapié y va bien con cualquier habitación de la casa.

#### ENGLISH

Practical floor and baseboard heater with an output of 1800W up to 2200W. Modern and elegant design that is well suited for both private and public use. Although very efficient, this electric convector is a little higher than a skirting board and goes well with any room in the house.

#### FRANÇAIS

Chauffe-sol et plinthe pratique d'une puissance de 1800W - 2200 W. Un design moderne et élégant qui convient aussi bien à un usage privé que public. Bien que très efficace, ce chauffage électrique est à peine plus haut qu'une plinthe et s'intègre parfaitement dans toutes les pièces de la maison.

#### DEUTSCH

Praktischer Fußboden- und Sockelheizkörper mit einer Leistung von 1800 W - 2200 W. Modernes und elegantes Design, das sich sowohl für den privaten als auch für den öffentlichen Bereich eignet. Obwohl sehr effizient, ist dieser elektrische Konvektor etwas höher als eine Sockelleiste und passt gut zu jedem Raum im Haus.

### DIMENSIONI

100-140x12,5x24 CM

### PESO

4,3/5,2/6,1 KG

### COLORE

Bianco

### TIPO DI CALORE

Convezione naturale dell'aria

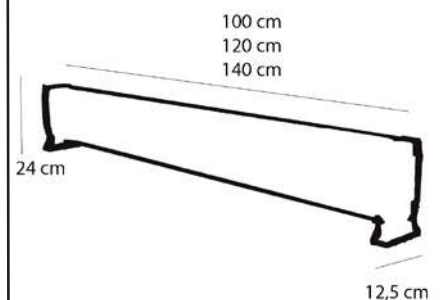





## CAMINETTI ELETTRICI A PAVIMENTO

*I caminetti da Pavimento Sined sono un elegante complemento per qualsiasi ambiente domestico, per la camera di un hotel o di un resort. Offrono il calore e l'atmosfera di una vera fiamma senza la necessità di combustibili tradizionali e di canne fumarie. Non sporcano come la legna e con il loro design moderno e raffinato, creano un'atmosfera accogliente e suggestiva, perfetta per rilassarsi e godersi momenti di tranquillità. Grazie alla loro praticità e facilità d'uso, rappresentano una soluzione ideale per riscaldare e abbellire gli spazi abitativi in modo innovativo.*

### ELECTRIC FLOOR STANDING FIREPLACES

*They are an elegant addition to any home environment. They offer the warmth and atmosphere of a real flame without the need for traditional fuels.*

*With their modern and refined design, they create a cosy and atmospheric atmosphere, perfect for relaxing and enjoying moments of tranquillity. Thanks to their practicality and ease of use, they represent an ideal solution for heating and beautifying living spaces in an innovative way.*

### CHEMINÉES ÉLECTRIQUES SUR PIED

*Elles constituent un complément élégant à tout environnement domestique. Ils offrent la chaleur et l'atmosphère d'une vraie flamme sans avoir recours aux combustibles traditionnels.*

*Grâce à leur design moderne et raffiné, ils créent une ambiance chaleureuse et atmosphérique, idéale pour se détendre et profiter de moments de tranquillité. Pour se détendre et profiter de moments de tranquillité. Grâce à leur praticité et à leur facilité d'utilisation, ils représentent une solution idéale pour chauffer et embellir les espaces de vie de manière innovante.*

### CHIMENEAS ELÉCTRICAS DE PIE

*Son un complemento elegante para cualquier ambiente doméstico. Ofrecen la calidez y el ambiente de una sin necesidad de combustibles tradicionales.*

*Con su diseño moderno y refinado, crean un ambiente acogedor y atmosférico, perfecto para relajarse y disfrutar de momentos de tranquilidad. Gracias a su practicidad y facilidad de uso, representan una solución ideal para calentar y embellecer los espacios vitales de forma innovadora.*

### ELEKTRISCHE STANDKAMINE

*Sie sind eine elegante Ergänzung für jede Wohnumgebung. Sie bieten die Wärme und Atmosphäre einer echten Flamme, ohne dass dafür herkömmliche Brennstoffe benötigt werden.*

*Mit ihrem modernen und raffinierten Design schaffen sie eine gemütliche und stimmungsvolle Atmosphäre, die perfekt zum perfekt zum Entspannen und Genießen von Momenten der Ruhe. Dank ihrer Zweckmäßigkeit und Benutzerfreundlichkeit sind sie eine ideale Lösung, um Wohnräume auf innovative Art und Weise zu beheizen und zu verschönern.*



# CAMINO-PIENZA

## ITALIANO

Elegante e conveniente, il modello PIENZA rappresenta l'essenza del design moderno. Composto da una cornice in legno e MDF con impiallaccatura, e un braciere elettrico da 1500W, questo caminetto elettrico interno si distingue per la sua finitura bianca crema multistrato.

## FRANÇAIS

Élégant et abordable, le modèle PIENZA représente l'essence même du design moderne. Composée d'un cadre en bois et MDF avec placage, et d'un brasier électrique de 1500W, cette cheminée électrique d'intérieur se distingue par sa finition multicouche blanc crème.

## ESPAÑOL

Elegante y asequible, el modelo PIENZA BIANCO representa la esencia del diseño moderno. Compuesta por un armazón de madera y MDF chapado y un brasero eléctrico de 1500 W, esta chimenea eléctrica de interior se distingue por su acabado multicapa de color blanco cremoso.

## DEUTSCH

Das elegante und erschwingliche Modell PIENZA BIANCO verkörpert die Essenz des modernen Designs. Dieser elektrische Innenkamin besteht aus einem Rahmen aus Holz und MDF mit Furnier und einem 1500W Elektrokoher und zeichnet sich durch seine cremeweiße Mehrschichtlackierung aus.

## ENGLISH

Elegant and affordable, the PIENZA model represents the essence of modern design. Consisting of a wood and MDF frame with veneer, and a 1500W electric brazier, this electric indoor fireplace is distinguished by its creamy white multi-layer finish.

**INCLUDE IL MODELLO CAMINETTO-VULCANO ALL'INTERNO.**



## DIMENSIONI

94,9x110x24,9 CM

## PESO

32,2 KG

## COLORE

Bianco, grigio scuro, nero, turchese

## TIPO DI CALORE

termoconvettore  
750-1500W



*EU directives compliance*  
LVD 2014/35/UE  
EMC 2014/30/UE  
DERP 2009/125/CE  
RoHS 2011/65/EU ((UE) 2015/863)



CAMINO-PIENZA-BIANCO / 8025431019577

CAMINO-PIENZA-GRIGIO-SCURO / 8025431019058

CAMINO-PIENZA-NERO / 8025431019041

CAMINO-PIENZA-TURCHESE / 8025431019584

BIANCO / RAL #9001



GRIGIO SCURO / RAL #7016



TURCHESE / RAL #5018



NERO / RAL #9005

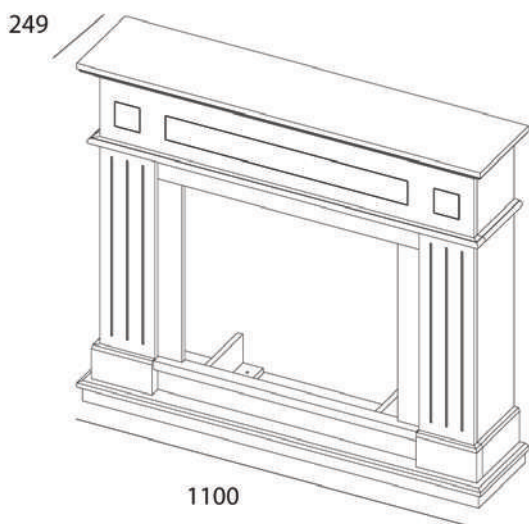

949

1100

(mm)





# CAMINO-CALDERA

## ITALIANO

Ottimo caminetto da pavimento per tutto l'anno, caratterizzato da un rivestimento multistrato di alta qualità. Il modello CALDERA finitura in diversi colori è un caminetto dal design esclusivo. Questo camino elettrico è l'aggiunta perfetta al tuo soggiorno, ufficio o camera da letto e può trasformare qualsiasi stanza in uno spazio elegante ed accogliente.

## FRANÇAIS

Une excellente cheminée au sol pour une utilisation tout au long de l'année, avec un revêtement multicouche de haute qualité. Le modèle CALDERA, fini en différentes couleurs, est une cheminée au design exclusif. Cette cheminée électrique est le complément parfait de votre salon, bureau ou chambre à coucher et peut transformer n'importe quelle pièce en un espace élégant et confortable.

## ESPAÑOL

Una excelente chimenea de pie para su uso durante todo el año, con un revestimiento multicapa de alta calidad. El modelo CALDERA acabado en diferentes colores es una chimenea de diseño exclusivo. Esta chimenea eléctrica es el complemento perfecto para su salón, oficina o dormitorio y puede transformar cualquier habitación en un espacio elegante y acogedor.

## DEUTSCH

Ein hervorragender bodenstehender Kamin für die ganzjährige Nutzung mit einer hochwertigen mehrschichtigen Verkleidung. Das Modell CALDERA in verschiedenen Farben ist ein exklusiv gestalteter Kamin. Dieser elektrische Kamin ist die perfekte Ergänzung für Ihr Wohnzimmer, Büro oder Schlafzimmer und kann jeden Raum in einen eleganten und gemütlichen Ort verwandeln.

## ENGLISH

An excellent floor-standing fireplace for all-year-round use, featuring a high-quality multi-layer cladding. The CALDERA model finished in different colours is an exclusively designed fireplace. This electric fireplace is the perfect addition to your living room, office or bedroom and can transform any room into an elegant and cosy space.

## DIMENSIONI

102,2x114x28,2 CM

## PESO

37,3 KG

## COLORE

Bianco, grigio, nero, turchese

## TIPO DI CALORE

termoconvettore  
750-1500W

**INCLUDE IL MODELLO  
CAMINETTO-VULCANO  
ALL'INTERNO.**



*EU directives compliance*  
LVD 2014/35/UE  
EMC 2014/30/UE  
DERP 2009/125/CE  
RoHS 2011/65/EU ((UE) 2015/863)



CAMINO-CALDERA-BIANCO / 8025431019447  
CAMINO-CALDERA-GRIGIO / 8025431019461  
CAMINO-CALDERA-NERO / 8025431019454  
CAMINO-CALDERA-TURCHESE / 8025431019478

BIANCO / RAL #9001



GRIGIO / RAL #7016



TURCHESE / RAL #5018



NERO / RAL #9005

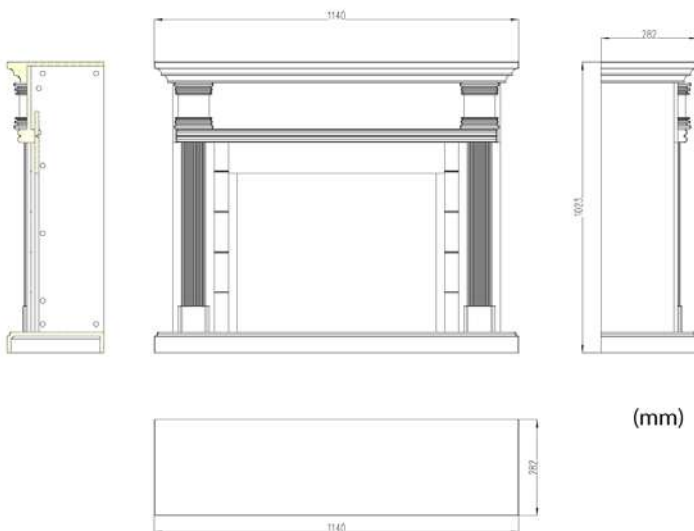



# CAMINO-CETONA

## ITALIANO

Caratterizzato da un rivestimento multistrato di alta qualità, il modello Cetona è un caminetto dal design premium. Questo camino elettrico è l'aggiunta perfetta al tuo soggiorno, ufficio o camera da letto e può trasformare qualsiasi stanza in uno spazio elegante ed accogliente.

## ESPAÑOL

Con un revestimiento multicapa de alta calidad, el acabado de Cetona es un diseño de chimenea de primera calidad. Esta chimenea eléctrica es el complemento perfecto para su salón, oficina o dormitorio y puede transformar cualquier habitación en un espacio elegante y acogedor.

## ENGLISH

Featuring a high-quality multilayer cladding, the Cetona finish is a premium fireplace design. This electric fireplace is the perfect addition to your living room, office or bedroom and can transform any room into an elegant and cosy space.

## FRANÇAIS

Dotée d'un revêtement multicouche de haute qualité, la finition Cetona est un modèle de cheminée haut de gamme. Cette cheminée électrique est le complément parfait de votre salon, bureau ou chambre à coucher et peut transformer n'importe quelle pièce en un espace élégant et confortable.

## DEUTSCH

Mit seiner hochwertigen mehrschichtigen Verkleidung ist der Cetona in Ausführung ein erstklassiges Kamindesign. Dieser elektrische Kamin ist die perfekte Ergänzung für Ihr Wohnzimmer, Büro oder Schlafzimmer und kann jeden Raum in einen eleganten und gemütlichen Ort verwandeln.

**INCLUDE IL MODELLO CAMINETTO-VULCANO ALL'INTERNO.**



## DIMENSIONI

102,2x114x28,2 CM

## PESO

37,3 KG

## COLORE

Bianco, grigio, nero, turchese, Wenge

## TIPO DI CALORE

termoconvettore

750-1500W



*EU directives compliance*

*LVD 2014/35/UE*

*EMC 2014/30/UE*

*DERP 2009/125/CE*

*RoHS 2011/65/EU ((UE) 2015/863)*



CAMINO-CETONA-NERO / 8025431019133  
CAMINO-CETONA-TURCHESE / 8025431019140  
CAMINO-CETONA-WENGHE / 8025431019164  
CAMINO-CETONA-BIANCO / 8025431019522  
CAMINO-CETONA-GRIGIO / 8025431150973

BIANCO / RAL #9001



GRIGIO / RAL #7016



TURCHESE / RAL #5018



NERO / RAL #9005



COLORE WENGE  
EDIZIONE LIMITATA

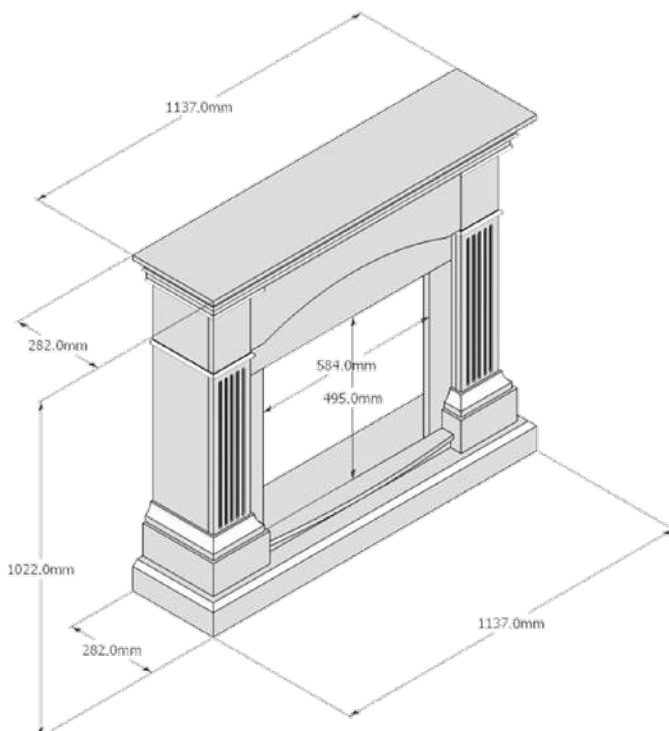



# CAMINO-LIPARI

## ITALIANO

Progettato e realizzato per un facile montaggio, non sono necessari strumenti extra, questo caminetto completo bianco crema ha un design che gli permette di essere posizionato in qualsiasi stanza, ufficio o locale anche di rappresentanza. Fornito di telecomando che imposta e regolatutte le funzioni ha un focolare molto potente 750-1500W.

## FRANÇAIS

Conçue et fabriquée pour un montage facile, sans outils supplémentaires, cette cheminée complète de couleur blanc crème a un design qui lui permet d'être placée dans n'importe quelle pièce, bureau ou locale, même représentative. Équipé d'une télécommande qui permet de régler et d'ajuster toutes les fonctions, il possède un foyer très puissant de 750-1500W.

## ESPAÑOL

Diseñada y fabricada para un fácil montaje, sin necesidad de herramientas adicionales, esta chimenea completa de color blanco cremoso tiene un diseño que permite colocarla en cualquier habitación, despacho o locale, incluso en una representativa. Equipado con un mando a distancia que fija y ajusta todas las funciones, tiene un hogar muy potente de 750-1500W.

## DEUTSCH

Entworfen und hergestellt für eine einfache Montage, kein zusätzliches Werkzeug ist erforderlich, diese cremeweiße komplette Kamin hat ein Design, das es erlaubt, in jedem Raum, Büro oder locale platziert werden, auch eine repräsentative ein. Ausgestattet mit einer Fernbedienung, mit der sich alle Funktionen einstellen und regeln lassen, verfügt er über eine sehr leistungsstarke 750-1500W.

## ENGLISH

Designed and manufactured for easy assembly, no extra tools are needed, this creamy white complete fireplace has a design that allows it to be placed in any room, office or locale, even a representative one. Equipped with a remote control that sets and adjusts all functions it has a very powerful 750-1500W.

**INCLUDE IL MODELLO CAMINETTO-VULCANO ALL'INTERNO.**



**DIMENSIONI**  
95x109x21,5 CM

**PESO**  
37,3 KG  
**COLORE**

Bianco, grigio, nero,  
turchese  
**TIPO DI CALORE**  
termoconvettore  
750-1500W



*EU directives compliance*  
LVD 2014/35/UE  
EMC 2014/30/UE  
DERP 2009/125/CE  
RoHS 2011/65/EU ((UE) 2015/863)





CAMINO-LIPARI-BIANCO / 8025431019485  
CAMINO-LIPARI-GRIGIO / 8025431019508  
CAMINO-LIPARI-NERO / 8025431019492  
CAMINO-LIPARI-TURCHESE / 8025431019515

BIANCO / RAL #9001



GRIGIO / RAL #7016



TURCHESE / RAL #5018



NERO / RAL #9005

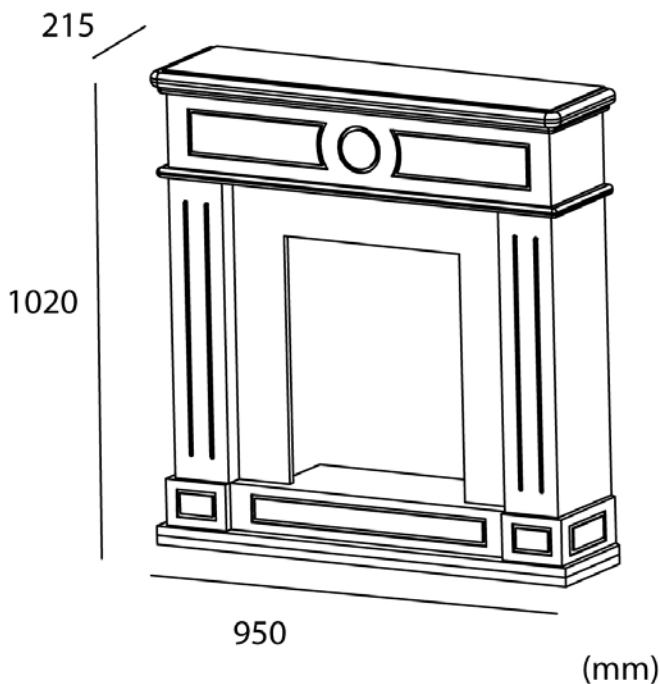



CAMINO-SIENA-BEIGE / 8025431019072  
 CAMINO-SIENA-BIANCO / 8025431019126  
 CAMINO-SIENA-BIANCO-CREMA / 8025431019089  
 CAMINO-SIENA-GRIGO-SCURO / 8025431019096  
 CAMINO-SIENA-ROVERE / 8025431019102  
 CAMINO-SIENA-WENGE / 8025431019119



**BEIGE**



**BIANCO**



**BIANCO CREMA**



**WENGE**



**ROVERE**



**GRIGO-SCURO**

**INCLUDE IL MODELLO CAMINETTO-VULCANO ALL'INTERNO.**

**ITALIANO**

Facile la sua installazione in qualsiasi ambiente e la manutenzione nel tempo. Il caminetto elettrico è fornito di telecomando che controlla tutte le funzioni del camino elettrico. Oltre che con il telecomando potrai scegliere le varie opzioni anche dal pannello frontale.

**ESPAÑOL**

Fácil de instalar en cualquier entorno y de mantener en el tiempo. La chimenea eléctrica está equipada con un mando a distancia que controla todas sus funciones. Además del mando a distancia, también puedes elegir las distintas opciones desde el panel frontal.

**ENGLISH**

Easy to install in any environment and maintain over time. The electric fireplace is equipped with a remote control that controls all its functions. In addition to the remote control, you can also choose the various options from the front panel.

**FRANÇAIS**

Installation facile dans n'importe quel environnement et maintenance dans le temps. La cheminée électrique est équipée d'une télécommande qui contrôle toutes ses fonctions. En plus de la télécommande, vous pouvez également choisir les différentes options à partir du panneau avant.

**DEUTSCH**

Einfache Installation in jeder Umgebung und Wartung im Laufe der Zeit. Der Elektrokaamin ist mit einer Fernbedienung ausgestattet, die alle Funktionen steuert. Außer über die Fernbedienung können Sie die verschiedenen Optionen auch über das Bedienfeld auswählen.



**DIMENSIONI**  
95,2x107,2x24,5 CM

**PESO**  
37,3 KG

**COLORE**  
Beige, bianco, bianco crema, wenge, rovere, grigio scuro

**TIPO DI CALORE**  
termoconvettore  
750-1500W



*EU directives compliance*  
LVD 2014/35/UE  
EMC 2014/30/UE  
DERP 2009/125/CE  
RoHS 2011/65/EU ((UE) 2015/863)

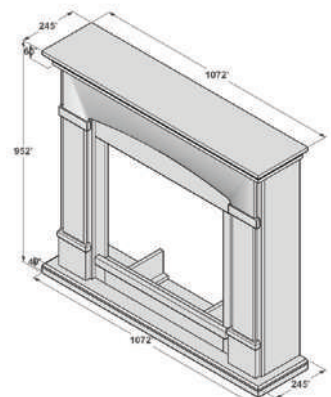



CAMINO-SORANO-AVORIO / 8025431019201  
 CAMINO-SORANO-BIANCO / 8025431019218  
 CAMINO-SORANO-GRIGIO-SCURO / 8025431019195  
 CAMINO-SORANO-NERO / 8025431019188



**BIANCO**



**AVORIO**



**GRIGIO SCURO**



**NERO**

**INCLUDE IL MODELLO CAMINETTO-VULCANO ALL'INTERNO.**



*EU directives compliance*  
 LVD 2014/35/UE  
 EMC 2014/30/UE  
 DERP 2009/125/CE  
 RoHS 2011/65/EU ((UE) 2015/863)

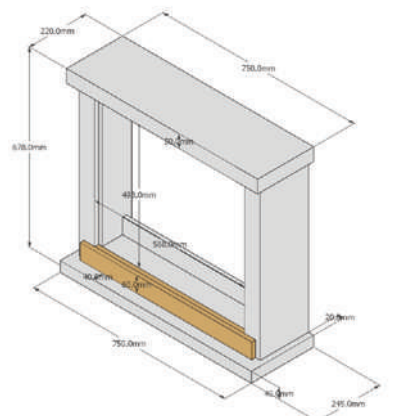

**ITALIANO**

Design semplice e compatto! Minimalista, dallo stile tipicamente nordico è uno dei nuovi camini elettrici più venduti sul mercato. Cornice realizzata in legno e MDF. La profondità di soli 25 cm lo rende poco ingombrante, perfetto per qualsiasi ambiente.

**ESPAÑOL**

Diseño sencillo y compacto Minimalista, de estilo típicamente nórdico, es una de las nuevas chimeneas eléctricas más vendidas del mercado. Marco de madera y MDF. La profundidad de sólo 25 cm hace que ahorre espacio, perfecto para cualquier habitación.

**ENGLISH**

Simple and compact design! Minimalist, typically Nordic in style, it is one of the best-selling new electric fireplaces on the market. Frame made of wood and MDF. The depth of only 25 cm makes it space-saving, perfect for any room.

**FRANÇAIS**

Un design simple et compact ! Minimaliste, de style typiquement nordique, c'est l'une des nouvelles cheminées électriques les plus vendues sur le marché. Cadre en bois et MDF. Sa profondeur de seulement 25 cm lui permet d'être peu encombrant et de s'adapter à toutes les pièces.

**DEUTSCH**

Einfaches und kompaktes Design! Der minimalistische, typisch nordische Stil macht ihn zu einem der meistverkauften neuen Elektrokamine auf dem Markt. Rahmen aus Holz und MDF. Mit einer Tiefe von nur 25 cm ist er platzsparend und passt perfekt in jeden Raum.



**DIMENSIONI**  
 67,8x75x24,5 CM

**PESO**  
 21,2 KG

**COLORE**  
 bianco, avorio,  
 grigio scuro, nero

**TIPO DI CALORE**  
 termoconvettore  
 750-1500W



CAMINO-ASCIANO-BEIGE / 8025431018990  
 CAMINO-ASCIANO-BIANCO / 8025431019034  
 CAMINO-ASCIANO-GRIGIO / 8025431019003  
 CAMINO-ASCIANO-GRIGIO-SCURO / 8025431019010  
 CAMINO-ASCIANO-ROVERE / 8025431019027



BIANCO

BEIGE

ROVERE



GRIGIO SCURO

GRIGIO

INCLUDE IL MODELLO CAMINETTO-VULCANO ALL'INTERNO.

ITALIANO

Caminetto elettrico da terra degno di nota, disponibile in diverse varianti di colore. Posizionabile in qualsiasi stanza sia in casa che in ambito commerciale. Fornito di telecomando che imposta e regola tutte le funzioni, ha un focolare molto potente 750-1500W con effetto fiamma, LED extra luminoso.

ESPAÑOL

Notable chimenea eléctrica de pie, disponible en diferentes variantes de color. Se puede colocar en cualquier habitación del hogar o del entorno comercial. Equipado con un mando a distancia que fija y ajusta todas las funciones, tiene un hogar muy potente de 750-1500W con efecto de llama, LED extra brillante.

ENGLISH

Noteworthy floor-standing electric fireplace, available in different colour variants. It can be placed in any room in the home or commercial environment. Equipped with a remote control that sets and adjusts all functions, it has a very powerful 750-1500W firebox with flame effect, extra bright LED.

FRANÇAIS

Remarquable cheminée électrique sur pied, disponible en différentes variantes de couleurs. Il peut être placé dans n'importe quelle pièce de la maison ou de l'environnement commercial. Équipé d'une télécommande qui permet de régler et d'ajuster toutes les fonctions, il dispose d'un foyer très puissant de 750-1500W avec effet de flamme, LED extra brillant.

DEUTSCH

Bemerkenswerter bodenstehender Elektrokamin, erhältlich in verschiedenen Farbvarianten. Es kann in jedem Raum in der Wohnung oder im Geschäftsumfeld aufgestellt werden. Ausgestattet mit einer Fernbedienung, die alle Funktionen einstellt und regelt, verfügt er über eine sehr leistungsstarke 750-1500W Feuerstelle mit Flammeneffekt, extra helle LED.



**DIMENSIONI**  
88,3x99x25 CM

**PESO**  
28 KG

**COLORE**  
bianco, beige, rovere,  
grigio scuro, grigio

**TIPO DI CALORE**  
termoconvettore  
750-1500W



*EU directives compliance*  
 LVD 2014/35/UE  
 EMC 2014/30/UE  
 DERP 2009/125/CE  
 RoHS 2011/65/EU ((UE) 2015/863)

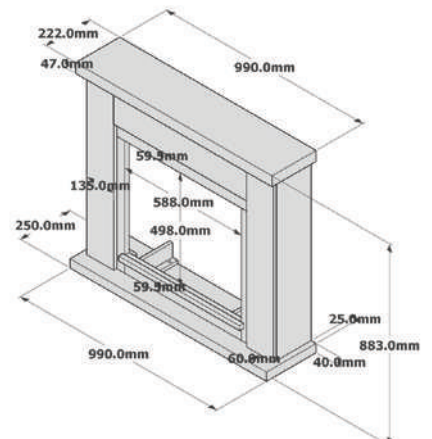



# CAMINO-MERAPI



8025431019539



## CAMINETTO A LIBERA INSTALLAZIONE.

AL SUO INTERNO UTILIZZARE IL MODELLO CAMINETTO-VULTURE-150.

### ITALIANO

Se cerchi un camino da terra importante, ottimo anche come complemento di arredo, questo è il grande camino elettrico bianco crema da pavimento modello Merapi, con realistico effetto fiamma realizzato mediante LED e regolabile come intensità, 6 livelli dal pratico telecomando a corredo.

### ESPAÑOL

Si busca una importante chimenea de pie, también excelente como accesorio de decoración, esta es la gran chimenea eléctrica de pie de color blanco crema modelo Merapi, con efecto de llama realista creado mediante LEDs y regulable en intensidad, 6 niveles por el práctico mando a distancia incluido.

### ENGLISH

If you are looking for an important floor fireplace, also excellent as a complement to furniture, this is the large electric fireplace creamy white floor model Merapi, with realistic flame effect made by means of LEDs and adjustable as intensity, 6 levels from the practical remote control included

### FRANÇAIS

Si vous recherchez une importante cheminée sur pied, également excellente comme accessoire d'ameublement, voici la grande cheminée électrique sur pied blanc crème modèle Merapi, avec un effet de flamme réaliste créé au moyen de LED et réglable en intensité sur 6 niveaux par la télécommande pratique incluse

### DEUTSCH

Wenn Sie auf der Suche nach einem wichtigen Standkamin sind, der sich auch hervorragend als Einrichtungsaccessoire eignet, dann ist dies der große cremeweiße elektrische Standkamin Modell Merapi, mit realistischem Flammeneffekt, der mit Hilfe von LEDs erzeugt wird und in der Intensität in 6 Stufen über die mitgelieferte praktische Fernbedienung einstellbar ist



**DIMENSIONI**  
200X83X33 CM

**PESO**  
40 KG

**COLORE**  
bianco

**TIPO DI CALORE**  
termoconvettore  
750-1500W



**Unici modelli in europa  
certificati e testati**

*EU directives compliance*

LVD 2014/35/UE

EMC 2014/30/UE

DERP 2009/125/CE

RoHS 2011/65/EU ((UE) 2015/863)

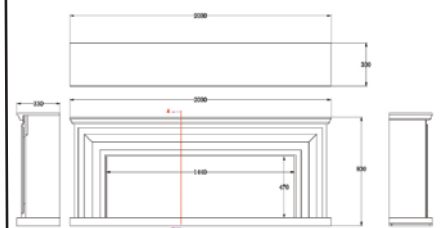

(mm)



# CORNICI IN LEGNO MDF *FACILI DA MONTARE!*

ACQUISTABILI ANCHE SEPARATAMENTE SENZA IL BRUCIATORE

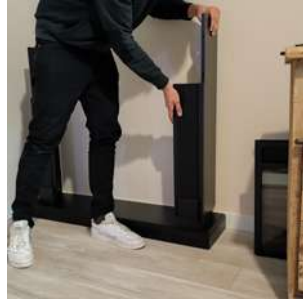

## CORNICE-CAMINO-CALDERA



-  **CORNICE-CAMINO-CALDERA-BIANCO**  
8025431019362 / RAL #9001
-  **CORNICE-CAMINO-CALDERA-GRIGIO**  
8025431019386 / RAL #7016
-  **CORNICE-CAMINO-CALDERA-NERO**  
8025431019379 / RAL #9005
-  **CORNICE-CAMINO-CALDERA-TURCHESE**  
8025431019393 / RAL #5018





## CORNICE-CAMINO-PIENZA



-  **CORNICE-CAMINO-PIENZA-BIANCO**  
8025431019577 / RAL #9001
-  **CORNICE-CAMINO-PIENZA-GRIGIO-SCURO**  
8025431019058 / RAL #7016
-  **CORNICE-CAMINO-PIENZA-NERO**  
8025431019041 / RAL #9005
-  **CORNICE-CAMINO-PIENZA-TURCHESE**  
8025431019584 / RAL #5018

## CORNICE-CAMINO-CETONA



-  **CORNICE-CAMINO-CETONA-BIANCO**  
8025431019324 / RAL #9001
-  **CORNICE-CAMINO-CETONA-GRIGIO**  
8025431019331 / RAL #7016
-  **CORNICE-CAMINO-CETONA-NERO**  
8025431019348 / RAL #9005
-  **CORNICE-CAMINO-CETONA-TURCHESE**  
8025431019355 / RAL #5018

## CORNICE-CAMINO-LIPARI



-  **CORNICE-CAMINO-LIPARI-BIANCO**  
8025431019485 / RAL #9001
-  **CORNICE-CAMINO-LIPARI-GRIGIO**  
8025431019508 / RAL #7016
-  **CORNICE-CAMINO-LIPARI-NERO**  
8025431019492 / RAL #9005
-  **CORNICE-CAMINO-LIPARI-TURCHESE**  
8025431019515 / RAL #5018



# MONTAGGIO SEMPLICE

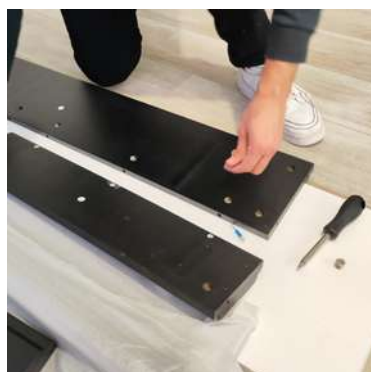
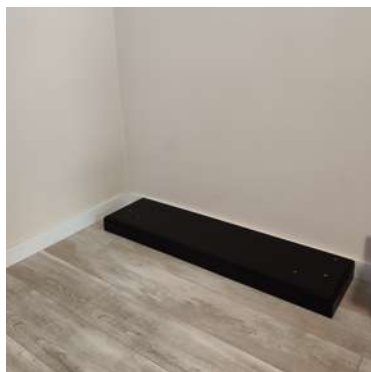



# SINED

**Italia: M.P.C. Srl**  
**Via Tortona 21 20144 Milano, Italia**

Logistica: Gruppo Sinergia  
Via Tavole di Casalbergo 7  
37063 Isola della Scala (VR)

**España: Sined V.O. S.L.U.**  
**Avenida Diagonal, 413 5º 2ª**  
**08008 Barcelona España**

Logistica: Stockabee  
Calle Tapiceros 5 Nave K  
28830 San Fernando de Henares Madrid

☎ TELEFONO IT +39 0221117815  
MOBILE IT +39 335 7600875  
MOBILE EN/FR +39 3425447140  
TELÉFONO ES +34 664 66 64 26  
TELÉFONO ES +34 664 66 64 28

🌐 SINEDITALIA.COM  
CAMINETTIDAPARETE.IT  
RISCALDATOREPERESTERNO.IT  
CHIMENEALECTRICAPARED.ES  
CALEFACTOREXTERIOR.ES

✉ INFO@SINEDITALIA.COM